

AXLE COMPONENTS

CARRIERS

Ford Racing offers a variety of nodular iron, steel and aluminum carriers for the popular 9" axle.

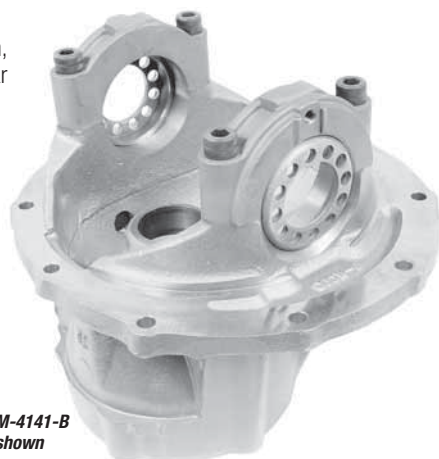

M-4141-B shown



M-4141-D shown

PART NUMBER	MATERIAL CARRIER	BRG. CAP	APPROX. WEIGHT	BRG. CAP I.D.	ADJUSTER NUT	DIFF. BRG.	DIFF. RACE	AXLE SHAFT COMPATIBILITY	NOTES
M-4141-B	Nodular Iron	4130 Steel	26#	2.892" Steel	Stamped Steel	LM-102949	LM-102910	28/31/33 Spline	Heavy Duty
M-4141-D	Aluminum	Aluminum	14#	3.0625"	Machined Steel	LM-603049	LM-603011	28/31/33 Spline	Heavy Duty
M-4141-E	Nodular Iron	4130 Steel	26#	3.0625" Steel	Machined Steel	LM-603049	LM-603011	28/31/33 Spline	Heavy Duty
M-4141-H	Nodular Iron	4130 Steel	26#	3.250"	Machined Steel	LM-104949	LM-104911	31/35/40 Spline	Heavy Duty Lightweight
M-4141-J	Nodular Iron	4130 Steel	26#	2.9528"	Machined Steel	2MM9109W1 Ball Bearings	—	31 Spline	Heavy Duty

9" STEEL DIFFERENTIAL CARRIER

M-4141-HS

- Developed using Finite Element Analysis (FEA) to withstand the demands of NASCAR racing. Finite Element Analysis is a method for predicting the response of a geometric structure due to the environment it is being designed to function in. The process starts by creating a geometric model. The model is then subdivided, or meshed into many small geometric pieces, or elements of basic geometric shape. These basic shapes can easily give results for stress and strain where the larger geometric structure cannot
- Steel casting has nearly double the tensile and yield strength and elongation vs. cast iron
- Case investment cast from 8620 steel
- Bearing caps machined from 4130 steel
- ARP® bolts
- 3.250" differential bearing diameter
- Approximate weight: 21 lbs.

